



AUTORISE
TOUTE
CRÉATIVITÉ

MANUFACTURE DE CRÉATIONS DE
STRUCTURES ÉVÉNEMENTIELLES

NOS STRUCTURES EVENT



POUR DES ESPACES
D'EXPOSITION ET DE
COMMUNICATION
TOTALEMENT
RECYCLABLES



100% RECYCLABLE

- + Fabriqué à partir de papiers recyclés FSC

LÉGER

- + Un carton alvéolaire 6 fois plus léger que le mdf
- + Optimisation des coûts de transport



SOLIDE

- + Résistance de 70kg par cm²

NOTRE MATERIAU

LE RE-BOARD®

LE RE-BOARD EST UNE SOLUTION D'IMPRESSION ÉCOLOGIQUE ET BIOSOURCÉE. LA STRUCTURE INTERNE DU PANNEAU PERMET DE LUI APPORTER UNE **RÉSISTANCE OPTIMALE** TOUT EN GARDANT LA POSSIBILITÉ DE LE FAÇONNER.

MANIPULATION SIMPLE

- + Montage rapide sans outil
- + Facile à déplacer
- + Chantiers propres



IGNIFUGE

- + Classé M2
- + Euroclasse C
- + Difficilement inflammable

PERSONNALISABLE

- + Facilement imprimable à partie de blanc, kraft, noir
- + Vernis protecteur en option

NOS STRUCTURES EVENT

1 LES CLOISONS

CLOISONS SIMPLES

#SIMPLE #RECTOSEUL

CLOISONS FINES R°V°

#FINESSE #RECTOVERSO

CLOISONS DOUBLES

#ÉPAIS #SANSTRANCHE

2 LES TOTEMS

TOTEMS PLATS

#DEMILUNE #SOCLEIMPRIMÉ #REMBORDÉ_

TOTEMS 3 FACES

#SIMPLE #TRIANGULAIRE

TOTEMS 4 FACES

#SIMPLE #CARRÉ

3 LES ARCHES

POTEAUX RENFORCÉS

#VISIBILITÉ #HAUTEUR

4 LES MINI STANDS POP-UP

COMPTOIR OBLIQUE

#COMPACT #MULTIFONCTION

COMPTOIR & ASSISES

#COMPACT #MULTIFONCTION

STAND PRESSE

#COMPLET #MULTIFONCTION

5 LES RÉSERVES

RÉSERVES AUTOPORTANTES

#FONCTIONNEL #SÉCURISÉ

6 LES COMPOSITIONS

AVEC COLLECTION LOOCK

#ESTHÉTIQUE #CHALEUREUX

AVEC COLLECTION WOLD

#ESTHÉTIQUE #W

AVEC COLLECTION STOCKHOLM

#ORIGAMI #SANSTRANCHE

LES CONSEILS DE NOS DESIGNERS

1 GAGNEZ DU TEMPS

Sélectionnez nos produits standards en fonction de vos usages et adaptez votre communication graphique à nos gabarits d'impression prêts à l'emploi.

2 MOINS C'EST MIEUX LES FORMES

Dans un même espace, harmonisez les gammes de produits. Utilisez plutôt une collection par espace pour ne pas le saturer en informations visuelles.

3 MOINS C'EST MIEUX LES COULEURS

Pour une meilleure visibilité et une communication impactante, évitez de multiplier les couleurs sur les volumes. Privilégiez 3 couleurs maximum.

Harmonisez vos couleurs avec la base Re-board choisie (blanc, kraft ou noir). Par exemple, pour le kraft et les tranches apparentes, utilisez des couleurs complémentaires au marron.

4 DU CARTON JUSQU'À L'ESPACE DE VIE

Pour harmoniser vos espaces et les rendre plus vivants et agréables, agrémentez vos structures Re-board avec des plantes, éclairages (lampes) et accessoires textiles.

LES CLOISONS AUTOPORTANTES



CLOISON SIMPLE
RECTO



CLOISON FINE
RECTO VERSO



CLOISON DOUBLE
RECTO VERSO

**LES CLOISONS
AUTOPORTANTES**

**CLOISON SIMPLE
RECTO**



Cloisons simples recto
(L) 2000 x (H) 2300 x (P) 355

CLOISON SIMPLE RECTO

(L)2000 x (H)2300 x (P)355

Une cloison en impression recto rapide et facile à monter.

Finition sans tranche apparente et système de parois pliées de 1m, à associer.

INFORMATIONS POUR MONTAGE

Montage sans outils, sans collage, sans vis

Simplicité de montage 5/5



5 min



14 kg

IMPRESSON RECTO SEULE | VISIBILITÉ RECTO SEULE

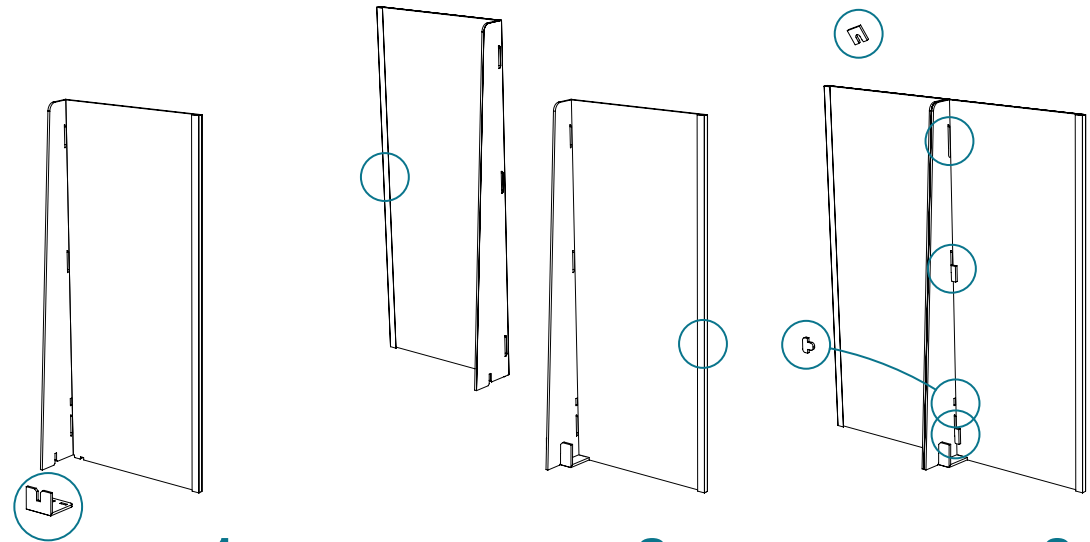

1

ALIGNEMENT PROPRE
GUIDAGE AU SOL

2

CÔTÉS REMBORDÉS
TRANCHES NON VISIBLES

3

ASSEMBLAGE FACILE
VERROUS À L'ARRIÈRE

LES FORMATS STANDARD

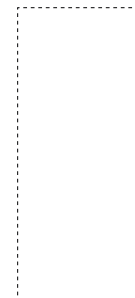
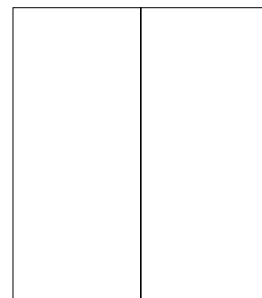

2000 x 2300 14 kg

3000 x 2300 21 kg

4000 x 2300 28 kg

5000 x 2300 35 kg

**LES CLOISONS
AUTOPORTANTES**

**CLOISON FINE
RECTO VERSO**



Cloison fine recto verso
(L) 3600 x (H) 2050 x (P) 300

CLOISON FINE RECTO VERSO

(L)3000 x (H)2000 x (P)300

Une cloison imprimée recto verso,
rapide et facile à monter.

Système de socles de 1,5m à associer.
Tranches apparentes sur les côtés.

INFORMATIONS POUR MONTAGE

Montage sans outils, sans collage, sans vis

Simplicité de montage 5 / 5



7 min



14 kg

IMPRESSION
RECTO VERSO

VISIBILITÉ
RECTO VERSO

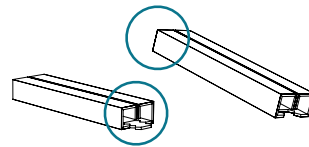

1
SOCLE
IMPRIMÉ
À COMPOSER

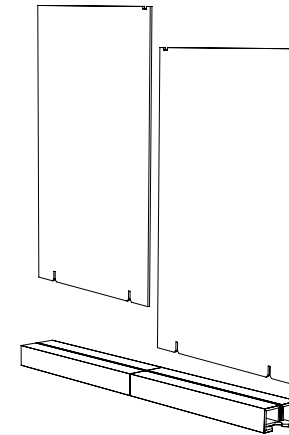

2
CLOISON
IMPRIMÉE
RECTO VERSO

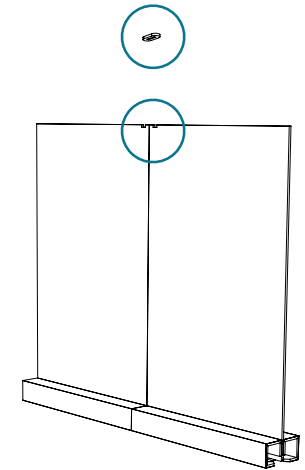

3
ALIGNEMENT
FACILE

LES FORMATS STANDARD

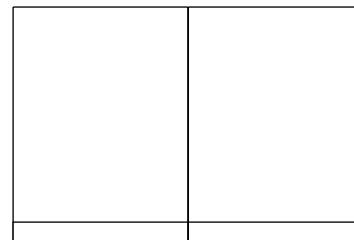

+

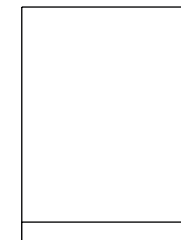

1500 x 2000 10 kg

3000 x 2000 20 kg

4500 x 2000 30 kg

6000 x 2000 40 kg

**LES CLOISONS
AUTOPORTANTES**

**CLOISON DOUBLE
RECTO VERSO**



Cloison double recto verso
(L) 4800 x (H) 2300 x (P) 400

CLOISON DOUBLE RECTO VERSO (L)2400 x (H)2300 x (P)400

Une cloison en double paroi
pour une visibilité à 360°.

Système de grands blocs de 1,2m de
large à associer.
Finition sans tranches apparentes sur
les côtés.

INFORMATIONS POUR MONTAGE

Montage sans outils, sans collage, sans vis

Simplicité de montage 3 / 5



10 min



14 kg

IMPRESSON
RECTO SEULE

VISIBILITÉ
RECTO VERSO

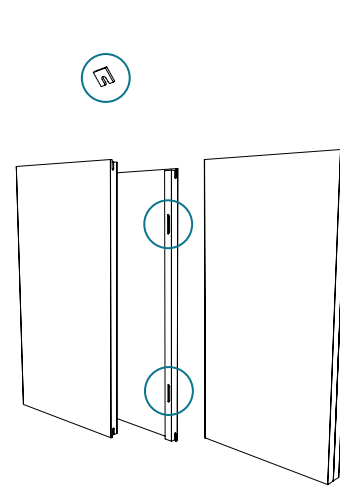

1
ASSEMBLAGE
INTÉRIEUR
VERROUS INVISIBLES

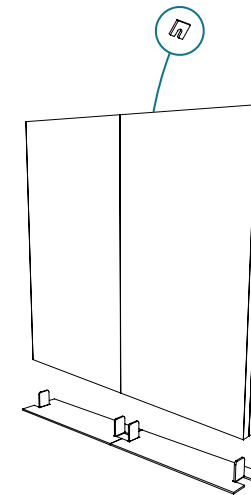

2
PLATINE DISCRÈTE
IMPRIMÉE

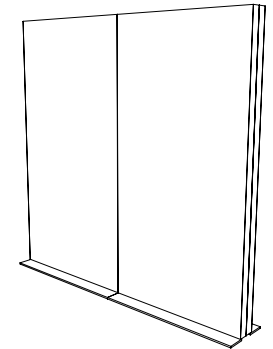

3
CÔTÉS REMBORDÉS
TRANCHES NON VISIBLES

LES FORMATS STANDARD

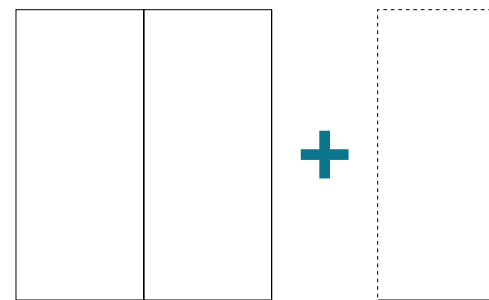

1200 x 2300 14 kg

2400 x 2300 21 kg

3600 x 2300 28 kg

4800 x 2300 35 kg

LES TOTEMS



PLAT
PIEDS
DEMI-LUNE



PLAT
SOCLE
IMPRIMÉ



PLAT
TOUT
REMBORDÉ

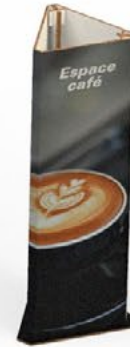

3
FACES



4
FACES

LES TOTEMS
PLATS

PIEDS
DEMI-LUNE



Totem pied demi-lune
(L) 740 x (H) 2000 x (P) 400

TOTEMS PLATS PIEDS DEMI-LUNE

Un totem simple et économique.

Une facilité de montage évidente.
Une verticalité impeccable.

INFORMATIONS POUR MONTAGE

Montage sans outils, sans collage, sans vis

Simplicité de montage 5 / 5



3 min



3-7 kg

IMPRESSION
RECTO VERSO

VISIBILITÉ
RECTO VERSO

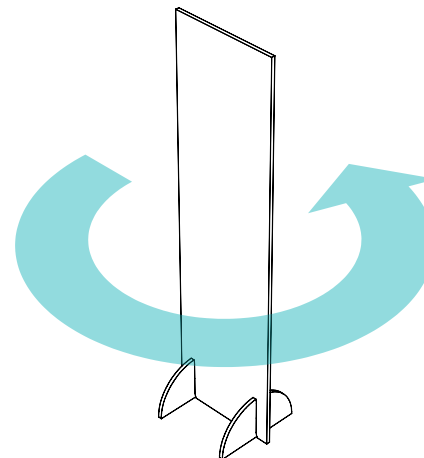

TOUS LES FORMATS STANDARD



490 x 1800 x 400

kg 3

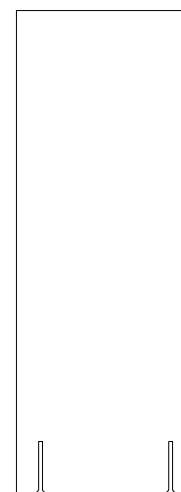

740 x 2000 x 400

kg 5

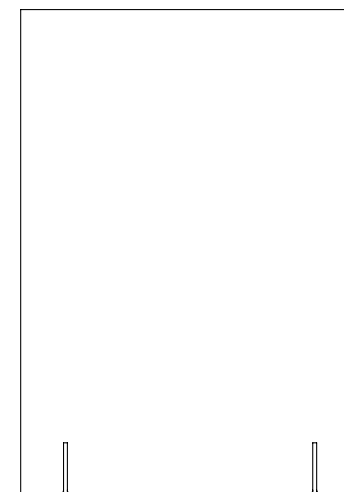

1400 x 2000 x 400

kg 7

LES TOTEMS
PLATS

SOCLE
IMPRIMÉ



Totem socle imprimé
(L) 740 x (H) 1800 x (P) 300

TOTEMS PLATS SOCLE IMPRIMÉ

Un totem simple et robuste.

Un socle qui ajoute une surface de communication utile, garantissant une meilleure stabilité dans les lieux de passage.

INFORMATIONS POUR MONTAGE

Montage sans outils, sans collage, sans vis

Simplicité de montage 5 / 5



5 min



3-7 kg

IMPRESSION
RECTO VERSO

VISIBILITÉ
RECTO VERSO

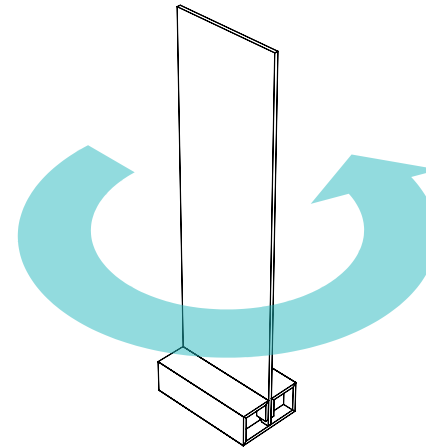

TOUS LES FORMATS STANDARD

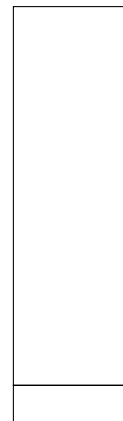

490 x 1700 x 300

kg 3

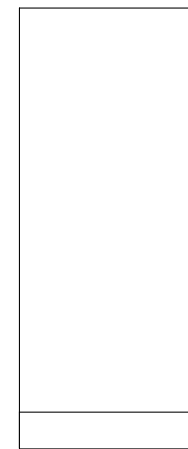

740 x 1800 x 300

kg 5

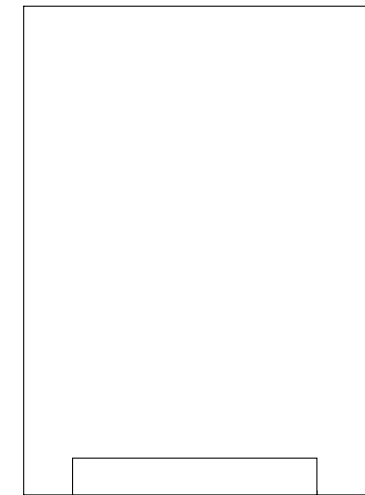

1400 x 2000 x 300

kg 7

LES TOTEMS
PLATS

TOUT
REMBORDÉ



Totem rebordé
(L) 1000 x (H) 2000 x (P) 250

TOTEMS PLATS TOUT REMBORDÉ

Un totem élégant et robuste.

Finition intégralement lisse sans tranche apparente.
Un socle stylisé garantissant une meilleure stabilité dans les lieux de passage.

INFORMATIONS POUR MONTAGE

Montage sans outils, sans collage, sans vis

Simplicité de montage

4 / 5



5 min



10-14 kg

IMPRESSION
RECTO SEULE

VISIBILITÉ
RECTO VERSO

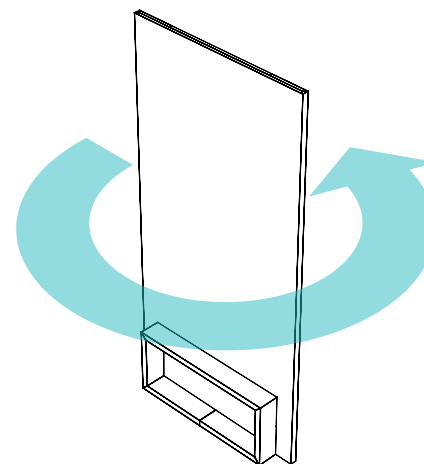

TOUS LES FORMATS STANDARD

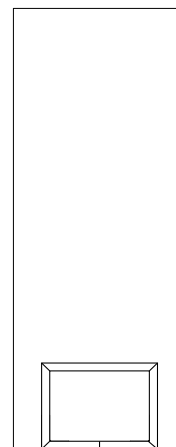

700 x 1800 x 250

kg 10

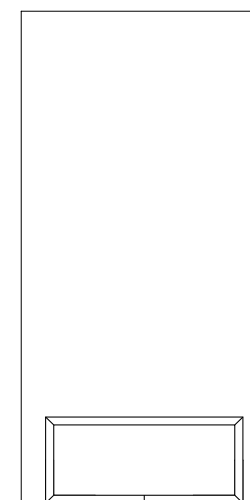

1000 x 2000 x 250

kg 14

LES TOTEMS

3 FACES



Totem 3 faces
(L) 775 x (H) 2000 x (P) 660

TOTEMS 3 FACES

Un totem triangulaire optimisé pour le montage.

La platine discrète sert de guidage au sol pour un montage facile et une finition impeccable.

INFORMATIONS POUR MONTAGE

Montage sans outils, sans collage, sans vis

Simplicité de montage 3 / 5



10 min



7-21kg

IMPRESSION
RECTO SEULE

VISIBILITÉ
360°

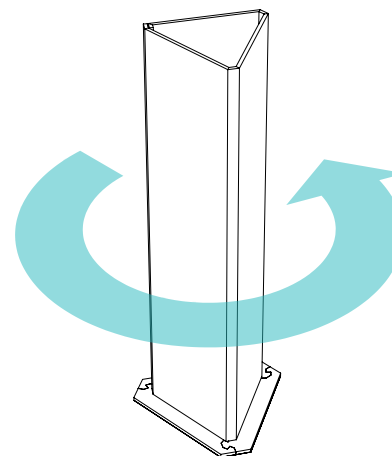

TOUS LES FORMATS STANDARD

faces de 450 x 1800
une arête avec
tranche visible

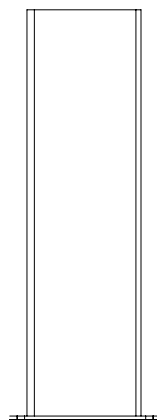

670 x 1800 x 580

kg 7

faces de 580 x 2000

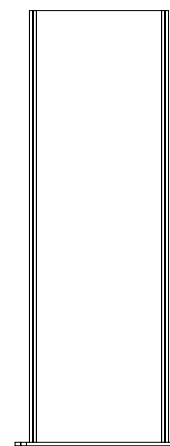

775 x 2000 x 660

kg 14

faces de 1000 x 2300

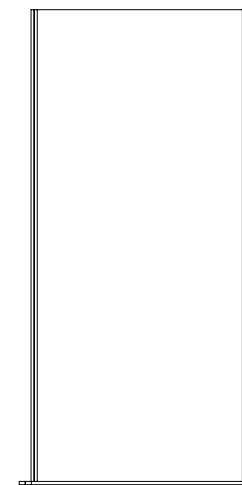

1175 x 2300 x 1020

kg 21

LES TOTEMS

4 FACES



Totem 4 faces
(L) 740 x (H) 2000 x (P) 740

TOTEMS 4 FACES

Un totem carré optimisé pour le montage.

La platine discrète sert de guidage au sol pour un montage facile et une finition impeccable.

INFORMATIONS POUR MONTAGE

Montage sans outils, sans collage, sans vis

Simplicité de montage

3 / 5



10 min



7-21kg

IMPRESSION
RECTO SEULE

VISIBILITÉ
360°

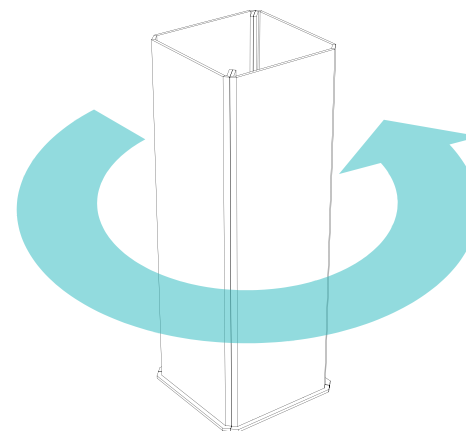

TOUS LES FORMATS STANDARD

faces de 600 x 2000

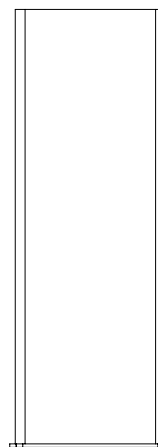

740 x 2000 x 740

kg 14

faces de 1200 x 2200

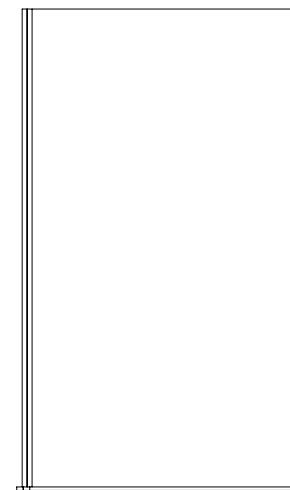

1340 x 2200 x 1340

kg 28

LES ARCHES



Arche renforcée
(L) 3000 x (H) 2300 x (P) 340

ARCHES POTEAUX RENFORCÉS

Des arches de communication renforcées.

Une construction sobre et résistante.
Les poteaux ont une trappe sur le côté intérieur pour insérer un lestage.

INFORMATIONS POUR MONTAGE

Montage sans outils, sans collage, sans vis

Simplicité de montage 3 / 5



15 min



21-30 kg

IMPRESSION RECTO SEULE | VISIBILITÉ 360°

HAUTEUR MINIMUM DESSOUS 2050

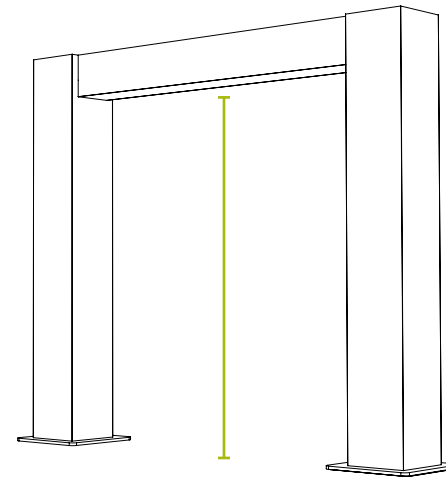

TOUS LES FORMATS STANDARD

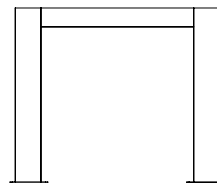

2700 x 2300 x 340

kg 21

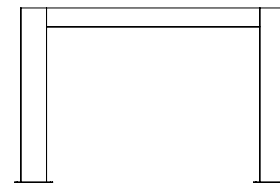

3400 x 2300 x 340

kg 27

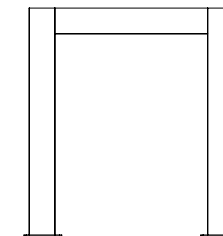

2700 x 3000 x 340

kg 27

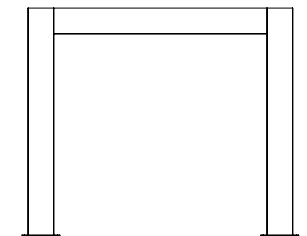

3400 x 3000 x 340

kg 30

LES MINI STANDS
POP-UP

POP-UP
**COMPTOIR
OBLIQUE**



Mini Stands Pop-Up Comptoir oblique
(L) 1150 x (H) 2300 x (P) 970

POP-UP COMPTOIR OBLIQUE

(L)1150 x (H)2300 x (P)970

Un mini-stand aux surfaces dynamiques.

Le comptoir se déploie de la paroi qui communique à 360°.

INFORMATIONS POUR MONTAGE

Montage sans outils, sans collage, sans vis

Simplicité de montage 3 / 5



10-15 min



14 kg

IMPRESSI
RECTO V

VISIBILITÉ
RECTO V

VUE
RECTO

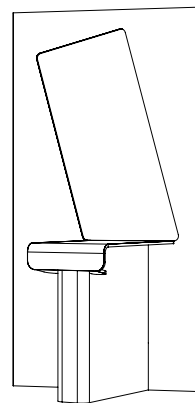

VUE
VERSO

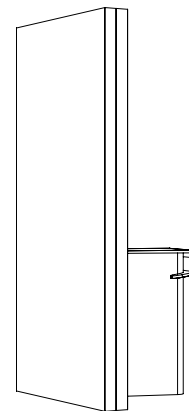

LARGEUR TABLE
500

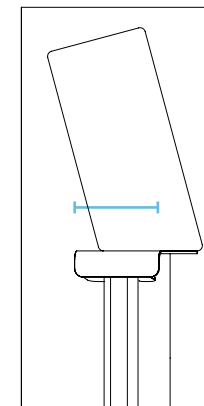

PROFONDEUR TABLE
780

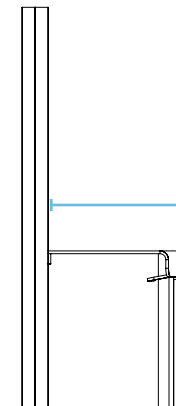

BASE RE-BOARD
BLANC



BASE RE-BOARD
KRAFT



BASE RE-BOARD
NOIR



LES MINI STANDS
POP-UP

POP-UP
**COMPTOIR
ASSISES**



Mini Stands Pop-Up Comptoir assises
Stand LYVE, Salon de l'entrepreneur (LYON)

POP-UP COMPTOIR ASSISES (L)1250 x (H)2300 x (P)600

Un mini-stand pour
présenter et échanger.

Le comptoir et assises se
déplient de la paroi qui
communiquent à 360°.

INFORMATIONS POUR MONTAGE

Montage sans outils, sans collage, sans vis

Simplicité de montage 3 / 5



15-20 min



14 kg

IMPRESSI
RECTO V

VISIBILITÉ
RECTO V

VUE
RECTO

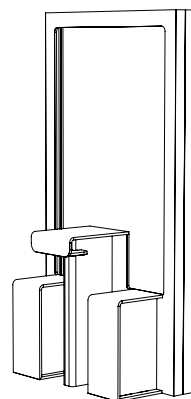

VUE
VERSO

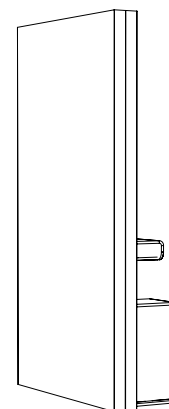

LARGEUR TABLE
380

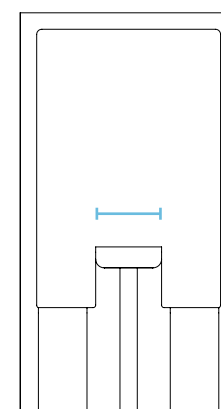

PROFONDEUR TABLE
580



BASE RE-BOARD
BLANC



BASE RE-BOARD
KRAFT



BASE RE-BOARD
NOIR



LES MINI STANDS
POP-UP

POP UP
STAND
PRESSE



Mini Stands Pop-Up Stand presse
(L) 1250 x (H) 2300 x (P) 1550

POP-UP STAND PRESSE (L)1250 x (H)2300 x (P)1550

Un petit stand pour
présenter et échanger.

Le comptoir et assises se
déplient des parois.
Des porte documents sont
intégrés à la structure qui
communiquent à 360°.

INFORMATIONS POUR MONTAGE

Montage sans outils, sans collage, sans vis

Simplicité de montage 3 / 5



25 min



35 kg

IMPRESSION
RECTO VERSO

VISIBILITÉ
RECTO VERSO

VUE
RECTO

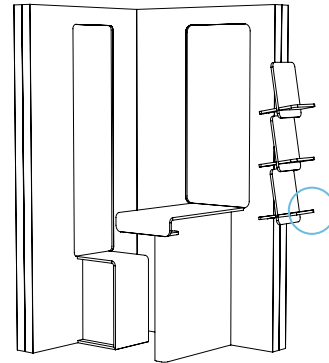

VUE
VERSO

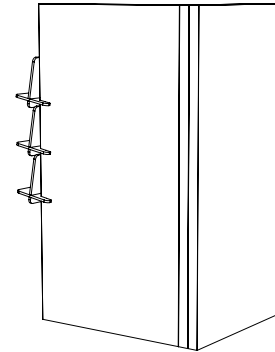

LARGEUR TABLE
380

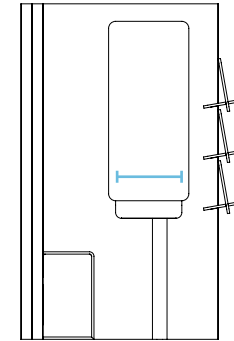

PROFONDEUR TABLE
580

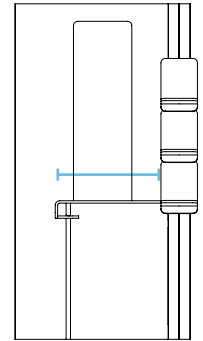

BASE RE-BOARD
BLANC



BASE RE-BOARD
KRAFT



BASE RE-BOARD
NOIR



LES RÉSERVES AUTOPORTANTES



Réserve
(L) 2000 x (H) 2000 x (P) 2000

RÉSERVES AUTOPORTANTES (L)2000 x (H)2350 x (P)2000

Une réserve équipée facile à monter

Plusieurs modèles fonctionnels
s'adaptant à la superficie du stand.

L'espace intérieur intègre plateaux
et porte manteaux.

La porte est sécurisée par verrou
barillet

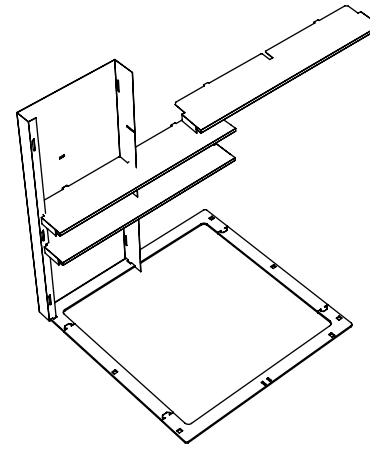

1
GUIDE AU SOL
CLOISON DE FOND ET
PLATEAUX DE STOCKAGE

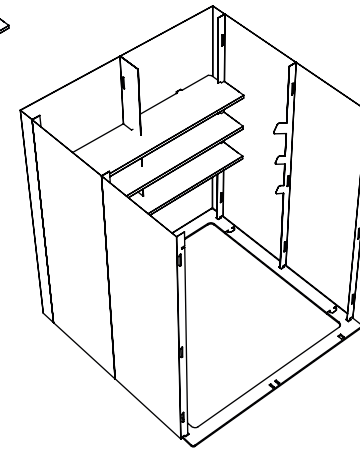

2
ASSEMBLAGE
INTÉRIEUR
VERROUS INVISIBLES

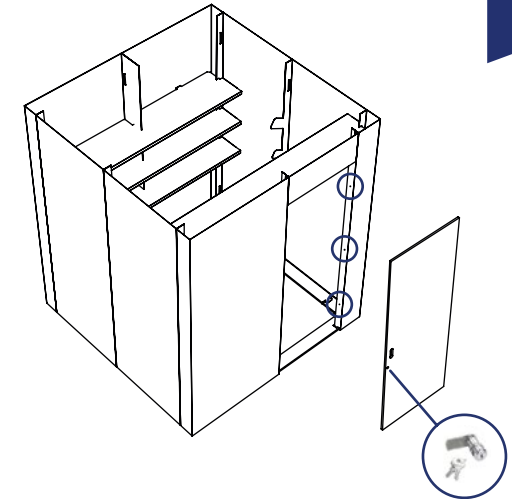

3
PORTE AMOVIBLE
SERRURE A BARILLET

LES FORMATS STANDARD

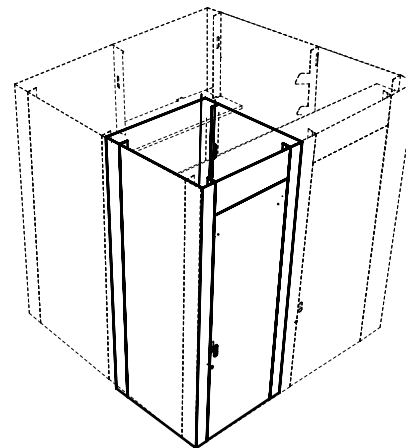

1000 x 1000 - Hauteur 2300  31

1500 x 1500 - Hauteur 2300  52

2000 x 2000 - Hauteur 2300  66

2000 x 2000 - Hauteur 3000  90

INFORMATIONS POUR MONTAGE

Montage sans outils, sans collage
Vis exclusivement pour la fixation de la porte

Simplicité de montage 4 / 5



25 min



66 kg

LES COMPOSITIONS
AVEC NOTRE
MOBILIER



La collection **LOOCK**
Un style épuré, aux formes rondes et réconfortantes.



La collection **WOLD**
Des jeux d'obliques tout en légèreté.



La collection **STOCKOLM**
Un style sobre avec peu de tranches apparentes.



La collection **EDGES**
Des formes organiques, douces et pleines de sens.

LA COLLECTION LOOCK



**TABOURET
BAS**



**TABOURET
HAUT**



CHAISE



BANC



TABLE BASSE



**MANGE
DEBOUT**



**GRANDE
TABLE**



**TABLE
CONFIDENCES**



CLOISON S



CLOISON ÎLOT

COMPOSEZ VOS ESPACES PERSONNALISÉS

En agencant nos cloisons et mobiliers
pour créer votre propre espace aux
couleurs de votre charte graphique.

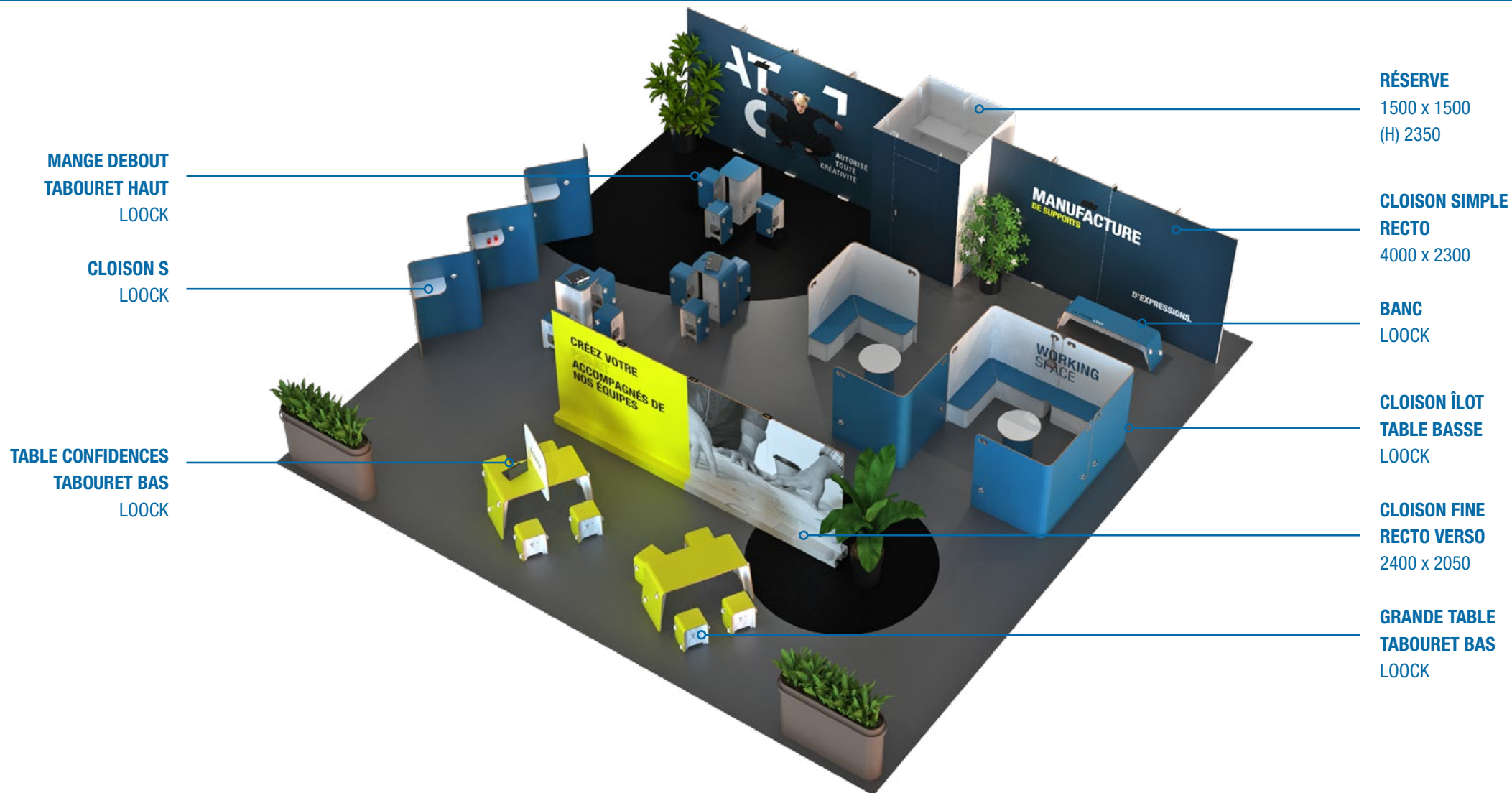

LA COLLECTION WOLD



**TABOURET
BAS**



**TABOURET
HAUT**



CHAISE



FAUTEUIL



BANC

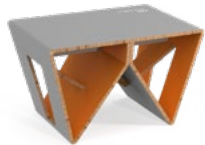

**TABLE
BASSE**



**MANGE
DEBOUT**



**GRANDE
TABLE**



**BANQUE
D'ACCUEIL**

COMPOSEZ VOS ESPACES PERSONNALISÉS

En agencant nos cloisons et mobiliers pour créer votre propre espace aux couleurs de votre charte graphique.



LA COLLECTION STOCKHOLM



TABOURET
BAS



TABOURET
HAUT



CHAISE



FAUTEUIL



BANC



TABLE
BASSE



TABLE DE
RÉCEPTION



GRANDE
TABLE



MANGE
DEBOUT



BANQUE
D'ACCUEIL



BANQUE D'ACCUEIL
AVEC TOTEM

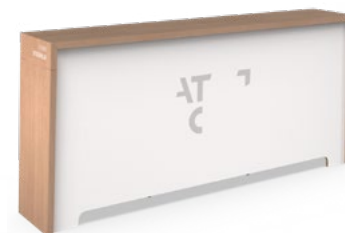

BAR



BAR D'ANGLE

COMPOSEZ VOS ESPACES PERSONNALISÉS

En agencant nos cloisons et mobiliers
pour créer votre propre espace aux
couleurs de votre charte graphique.

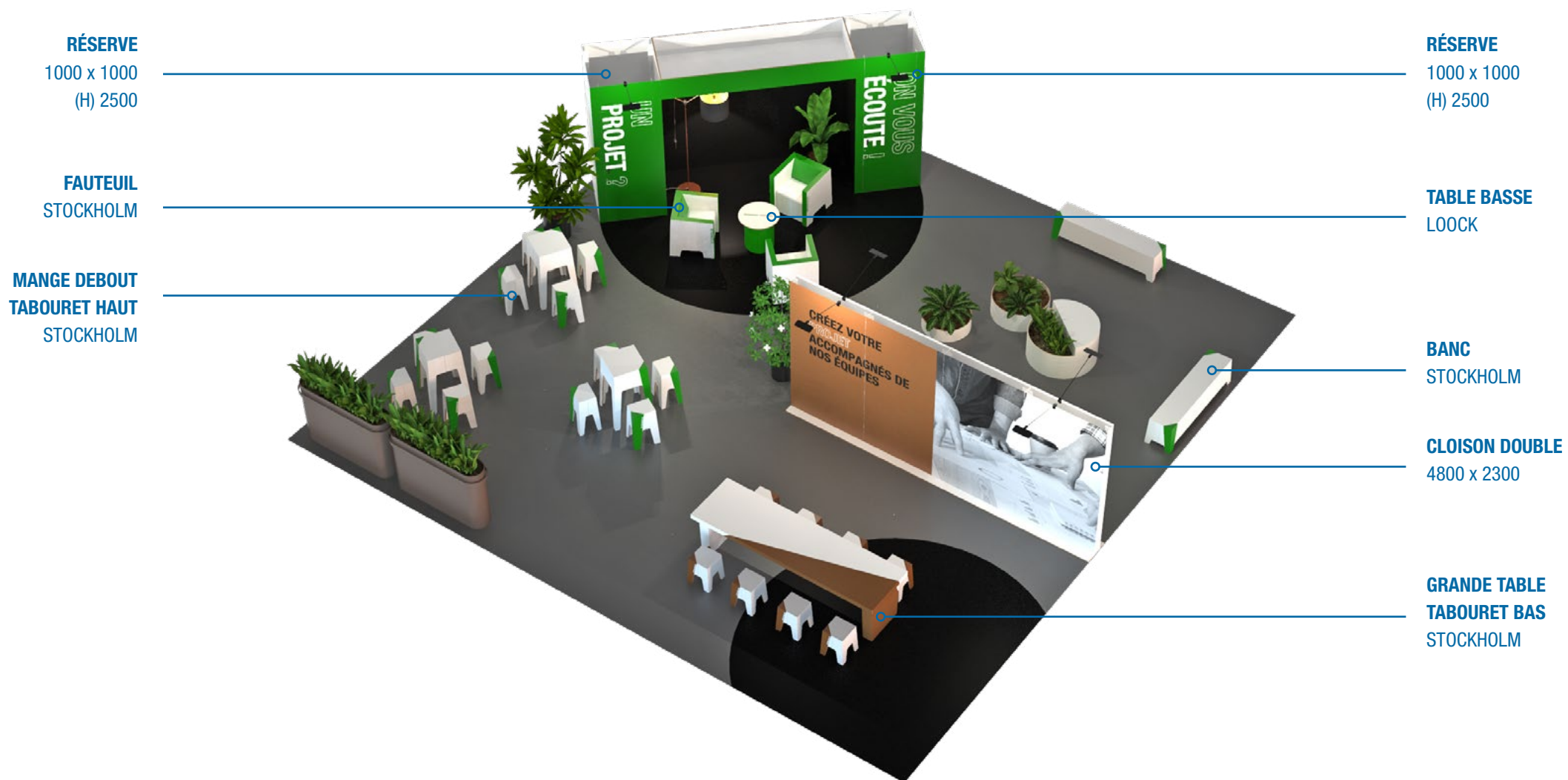

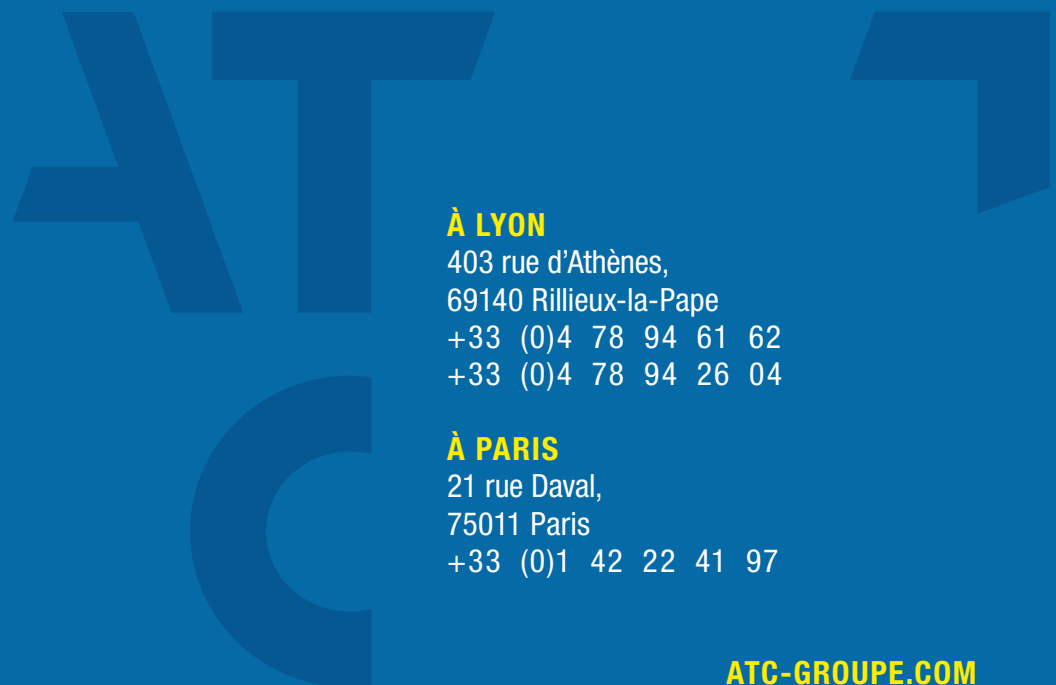

À LYON

403 rue d'Athènes,
69140 Rillieux-la-Pape
+33 (0)4 78 94 61 62
+33 (0)4 78 94 26 04

À PARIS

21 rue Daval,
75011 Paris
+33 (0)1 42 22 41 97

ATC-GROUPE.COM